

Ref. : VDI533022/306H330022 xx

LexCom Home® Data Switch S1000-T

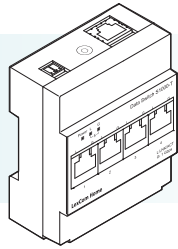

Attention!

- Phone cords & coax cords from the distribution center shall be disconnected before any manipulation.
- Distribution center shall always be connected to the "ground".
- CE seal shall not be damaged otherwise warranty will not be applied.
- Déconnecter le cordon téléphonique et le cordon coaxial du centre de distribution avant toute manipulation.
- Le centre de distribution doit être en permanence connecté à la terre.
- L'étiquette CE située sur le module sert de sceau. La rupture de ce sceau annulerait la garantie.
- Toevoerleidingen van telefoon en Tv in het verdeelcentrum dienen ontkoppeld te worden vóór elke manipulatie bij het installeren van deze module.
- Het verdeelcentrum dient steeds verbonden te zijn met de aarding.
- Het CE-label dient als verzegeling. Indien dit zegel beschadigd of verwijderd werd vervalt de garantie.

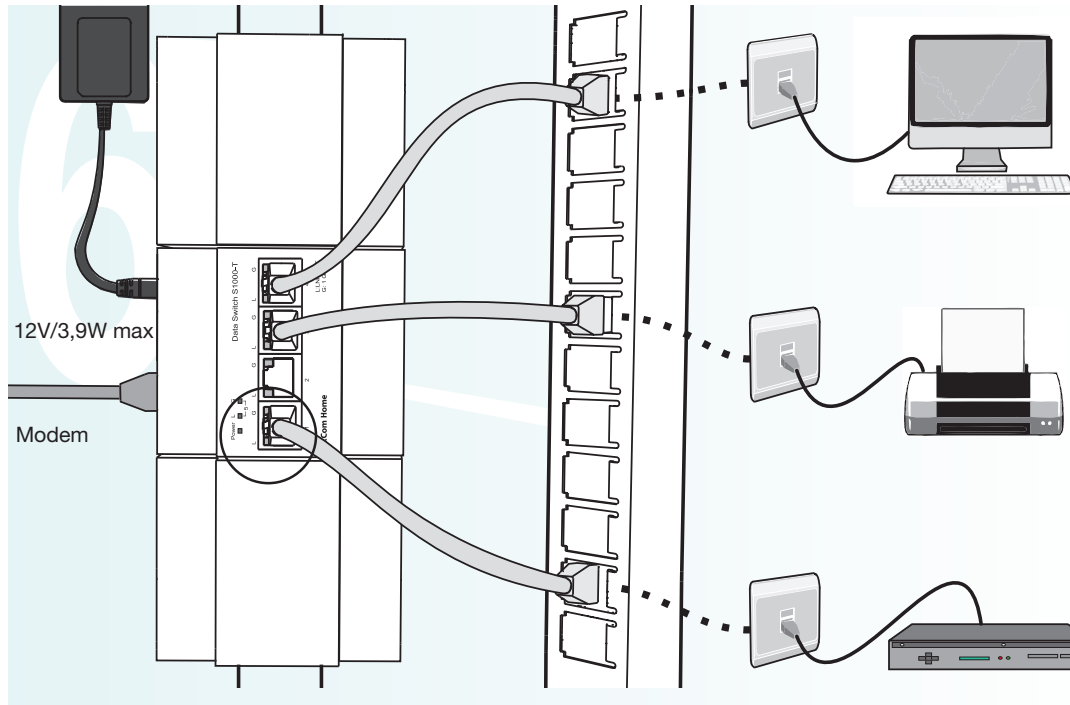
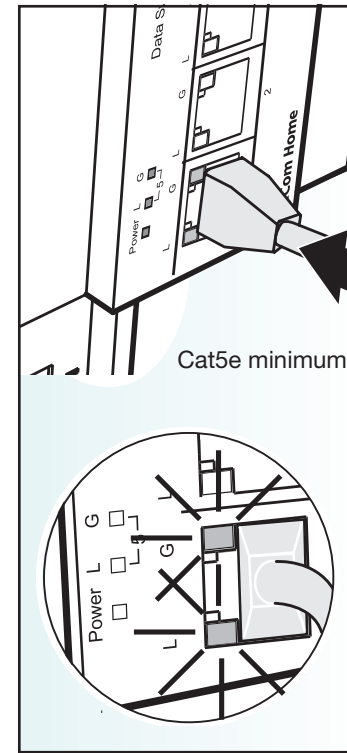
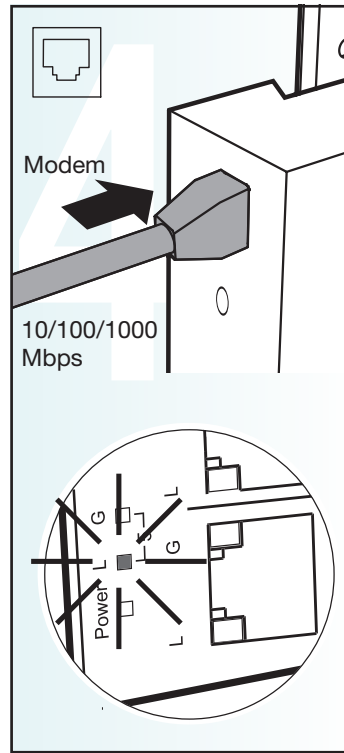
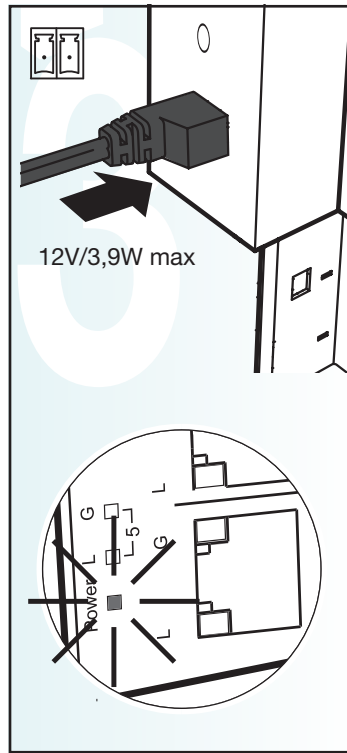

Technical specifications

Power supply/Alimentation/Voeding	12 V DC
Power consumption/Consommation électrique/Verbruik	Max. 3,9 W (DC)
Transmission speed/Vitesse de Transmission/Transmissiesnelheid	10/100/1000 Mbps
Operating temperature/Temperature de fonctionnement/Temperatuur tijdens bedrijf	0 °C to 45 °C
Operating humidity/Humidité de fonctionnement/Vochtigheidsgraad tijdens bedrijf	10% to 90% (non-condensing)
Dimensions/Afmetingen	71,8 x 85 x 37,3 mm (W x D x H)
EMI/IEM/EMI	FCC Class B, CE mark
Standards/Normes/Normeringen	EEE 802.3 10BASE-T Ethernet, IEEE 802.3u 100BASE-TX Fast Ethernet, IEEE 802.3ab Gigabit Ethernet, IEEE 802.3x Flow Control and Back Pressure, IEEE 802.1p Quality of Service

The LED's have the following indications:

LED/DEL/LED	Description/Omschrijving	Colour/Couleur/Kleur	Function/Fonction/Functie
Power	Power/Alimentation/Voeding	Green/Vert/Groen	On: Power on Allumé: Sous tension Aan: Onder spanning
L	Data Traffic/Liaison/Dataverkeer	Green/Vert/Groen	Off: Port not active/ Eteint: Port inactif/ Uit: Poort niet actief On: link established/ Allumé : liaison établie/ Aan: Verbinding tot stand gebracht Flashes: data traffic/ Clignotant: circulation de données/ Knippert: Dataverkeer
G	Port speed/Poortsnelheid	Green/Vert/Groen	Off: Port speed/ Eteint: Débit 10/100 Mbps/ Uit: Poortsnelheid 10/100 Mbps On: Port Speed/ Allumé: Débit 1 Gbps/ Aan: Poortsnelheid 1 Gbps

Schneider Electric Industries SAS
35, rue Joseph Monier
92500 Rueil-Malmaison, France
Tel : +33 (0)1 41 29 85 00
<http://www.schneider-electric.com>

This product must be installed, connected and used in compliance with prevailing standards and/or installation regulations. As standards, specifications and designs develop from time to time, always ask for confirmation of the information given in this publication.