

Touchpanel TW DALI

hidealite

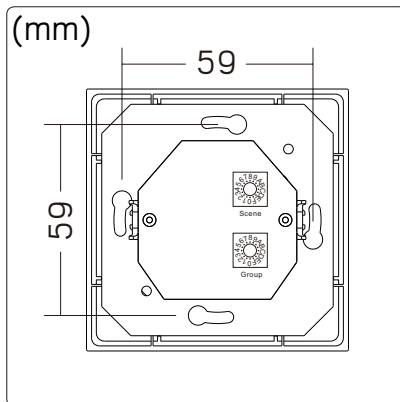

E-nr	Snro	El.nr	GTIN	Name
13 609 59	26 061 02	14 368 69	7392971149424	Touchpanel TW DALI

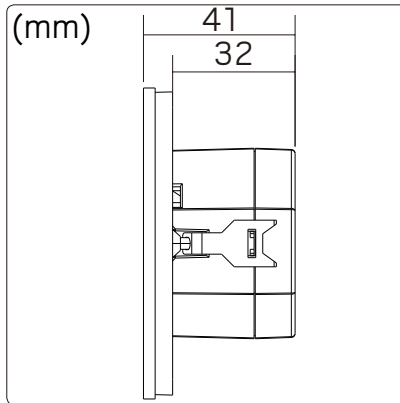
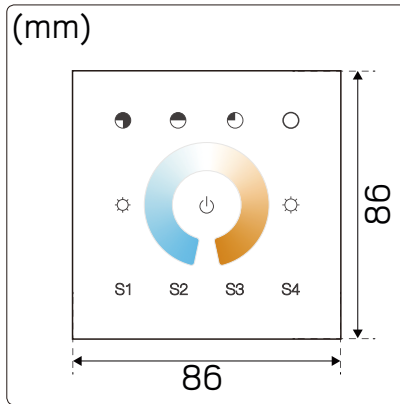
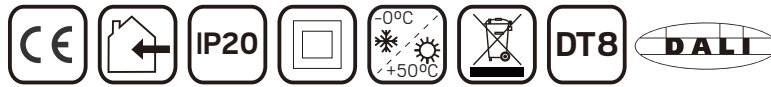

For explanation of symbols see www.hidealite.se

SAFETY INSTRUCTIONS

- en** Read these instructions carefully before commencing installation and retain for future reference. All connections to the driver must only be made by a qualified electrician or a person with the necessary expertise in electrical installation in accordance with the relevant rules and standards. Make sure that the power is off before installation or maintenance.
- sv** Läs dessa instruktioner före installationen påbörjas och lämna den vidare till brukaren av anläggningen. All anslutning till drivdonet får endast utföras av behörig elektriker eller person med nödvändig kännedom om elektrisk installation i enlighet med gällande regler och standarder till att spänningen är fränslagen före installation eller underhåll.
- fi** Lue nämä ohjeet ennen asentamista ja luovuta ohjeet valaisimen seuraavalle käyttäjälle. Kytkenät ohjaimien saa tehdä ainoastaan pätevä sähköasentaja tai sähköasennukset hallitseva henkilö voimassa olevien määräysten ja standardien mukaisesti. Varmista, että jännite on kytketty päältä ennen asennusta ja huoltoa.
- no** Les disse instruksjonene før du starter installeringen, og gi den deretter videre til anleggets bruker. All tilkobling til omformeren skal utføres av godkjent elektriker eller person med nødvendig kunnskap om elektrisk installasjon i henhold til gjeldende forskrifter og standard. Sørg for at strømmen er koblet fra før installering og ved vedlikehold.
- da** Læs disse anvisninger før du starter installationen og aflever vejledningen til anlæggets bruger. Alle tilslutninger på konverteren skal udføres af en autoriseret elinstallatør i overensstemmelse med gældende regler og standarder. Afbryd spænding før installation og vedligeholdelse.
- de** Lesen Sie diese Anweisungen sorgfältig, bevor Sie mit der Installation beginnen, und bewahren Sie sie für späteres Nachschlagen auf. Sämtliche Anschlüsse am Treiber dürfen nur von einem qualifizierten Elektriker oder einer Person mit der notwendigen Fachkenntnis im Bereich Elektroinstallationen und in Übereinstimmung mit den geltenden Richtlinien und Normen vorgenommen werden. Stellen Sie vor Installations- oder Wartungsarbeiten sicher, dass keine Spannung mehr anliegt.
- pl** **Przed przystąpieniem do instalacji należy się uważnie zapoznać z instrukcją i zachować ją na przyszłość. Wszystkie połączenia prowadzące do sterownika muszą zostać wykonane przez wykwalifikowanego elektryka bądź osobę posiadającą niezbędną wiedzę specjalistyczną w zakresie instalacji elektrycznych zgodnie z obowiązującymi przepisami i normami. Przed instalacją lub konserwacją wyłączyć zasilanie.**
- fr** Lisez attentivement ces consignes avant de commencer l'installation. Pensez également à vous y reporter ultérieurement. Tous les raccordements au moteur doivent uniquement être effectués par un électricien qualifié ou par un individu qui dispose de l'expertise requise en matière d'installation électrique, conformément aux normes et aux règles pertinentes. Veillez à couper le courant avant l'installation et toute opération de maintenance.

Fits mounting box

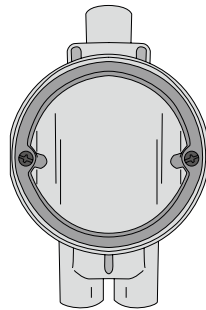

Rotary Switch for Assigning Scene (Total 16 Scenes)

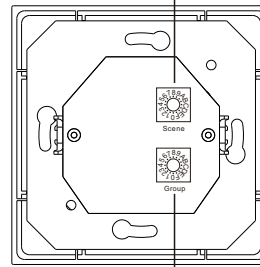

Rotary Switch for Assigning Group (Total 16 Groups)

Installation

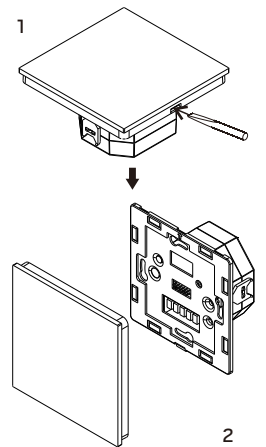

- DO NOT install with power applied to device.
- DO NOT expose the device to moisture.

- Installera INTE med ström ansluten till enheten.
- Utsätt INTE enheten för fukt.

Power supply	Output	Operation current	DALI bus output	DALI consumption	Ta	Relative humidity	Dimensions	IP Class
100-240VAC/DALI bus	DALI signal	<15 mA	100 mA max.	4 mA	0-40°C	8% to 80%	86x86x41mm	IP20

- Touch sensitive.
- Glass interface.
- Comply to DALI standard protocol IEC 62386-102, IEC 62386-207, IEC 62386-209 and in compliance with DALI products from other international incorporation
- Built-in 100mA DALI power supply to power up to max. 50 DALI ECGs.
- Powered by DALI bus while not connected to AC mains.
- Max. 100 DALI ECGs on a DALI line can be controlled by 4 control panels via broadcast (2 by AC mains, 2 by

- DALI bus).
- Enable to control 1 DALI Group and 4 DALI Scenes.
- Enable to set start DALI group number (0-15) and scene number (0-15) by rotary switches on the back.
- Support DT8 devices
- Color temperature adjustment according to DALI specifications of Device Type 8, Color Type Tc.
- Each DT8 device is controlled via a single DALI address

Operation

1. Set starting Group number via rotary switch on the back: (0-15 selectable)

This DALI touch panel controller enables dimming commands and DT8 commands to be sent to 1 Group of devices on the DALI circuit. A rotary switch on the back is used to select Groups you would like to control and set the starting Group number, and total 16 Groups (0-15) can be selected.

- When the rotary switch arrow position is at 0, the panel controls all DALI devices on the circuit via broadcast.
- When the rotary switch arrow position is at X except 0 (1-15), the panel controls DALI Group X-1.

Note: all DALI slaves on the circuit shall be assigned to one or more DALI groups by DALI master first.

Please refer to the detailed Group setting table as follows:

Rotary Switch Position	0	1	2	3	4	5	6	7	8	9	A	B	C	D	E	F
DALI Group Selected	Broadcast	0	1	2	3	4	5	6	7	8	9	10	11	12	13	14

2. Set starting Scene number via rotary switch on the back: (0-15 selectable)

• This DALI touch panel controller enables Scene selection commands for up to 4 Scenes to be sent to the DALI circuit. A rotary switch on the back is used to select Scenes you would like to control and set the starting scene number, and total 16 Scenes (0-15) can be selected.

• When the rotary switch arrow position is at X (0-15), Scene button S1 controls Scene X, S2 controls Scene X+1, S3 controls Scene X+2, and S4 controls Scene X+3.

Please refer to the detailed Scene setting table as follows:

Rotary Switch Position	0	1	2	3	4	5	6	7	8	9	A	B	C	D	E	F
Scene assigned to S1	0	1	2	3	4	5	6	7	8	9	10	11	12	13	14	15
Scene assigned to S2	1	2	3	4	5	6	7	8	9	10	11	12	13	14	15	0
Scene assigned to S3	2	3	4	5	6	7	8	9	10	11	12	13	14	15	0	1
Scene assigned to S4	3	4	5	6	7	8	9	10	11	12	13	14	15	0	1	2

Figure 1: Wiring scheme to control up to 50 DALI ECG via broadcast or control 1 DALI group.

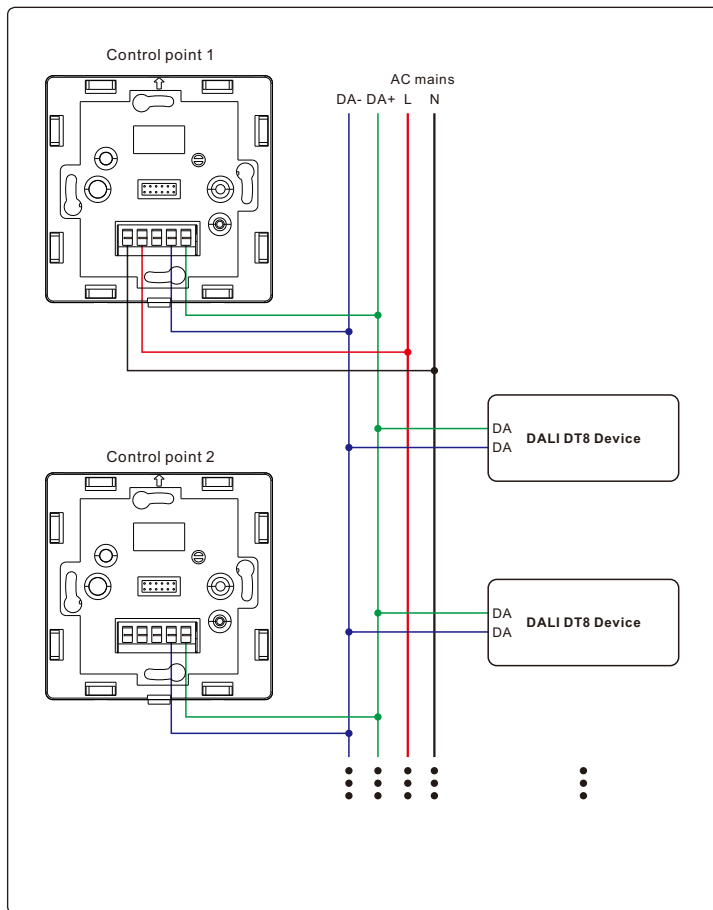
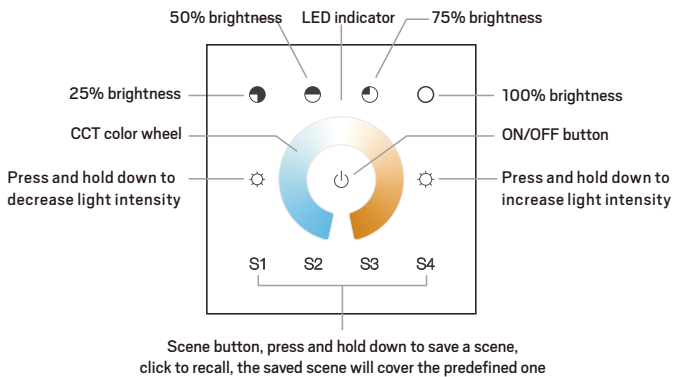
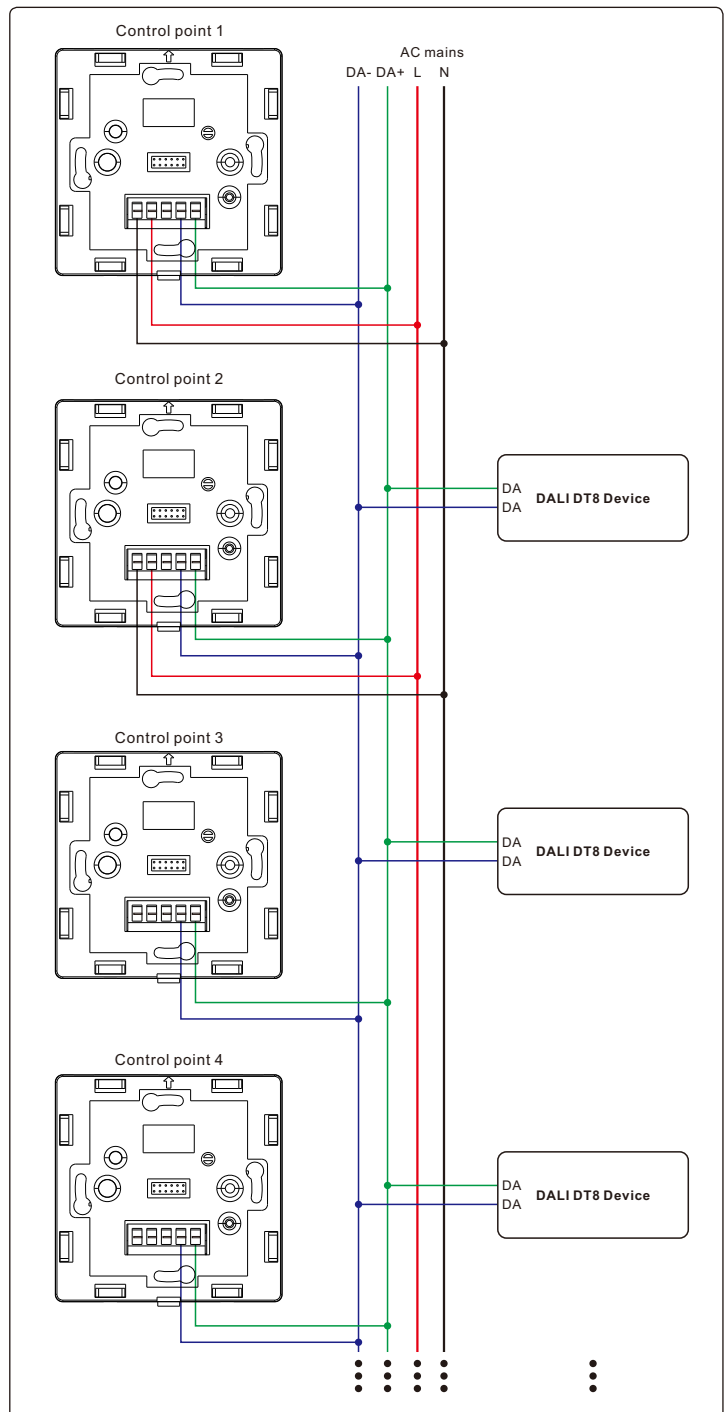

Figure 2: Wiring scheme with 2 DALI panels powered by AC mains to control up to 100 DALI ECG via broadcast or control 1 DALI group.



1. To control up to 100 ECG with the setup (Figure 2), there are 2 panels connected to AC mains.
 2. To control up to 50 ECG with the setup (Figure 1), there is only 1 panel connected to AC mains. Other panels are powered by DALI bus. Max. 2 DALI panels can be connected to AC mains in the same control circuit.